

Parallel grippers HGPT-B, heavy-duty

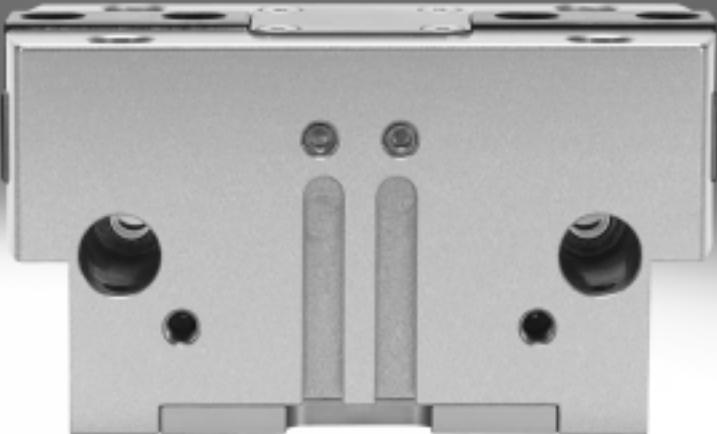

Parallel grippers HGPT-B, heavy-duty

Key features

Advantages compared with the parallel gripper HGPT

- **Space-optimised:**
Choice of shorter housing without gripping force retention or longer housing with gripping force retention
- **Increased gripping force/high-force variant:**
Gripping force increased by 30% by means of oval piston.
High-force variant also available: half the stroke, twice the force
- **Reduced weight:**
Systematic use of lighter and higher performance materials
- **4 sensor slots:**
Proximity sensors no longer project past the bottom of the housing.
Up to four positions can be sensed with the proximity sensors

At a glance

General information

Sturdy and precise kinematic system for maximum torque absorption and long service life.
The force generated by the linear motion is translated into the gripper jaw movement via a wedge mechanism

with guided motion sequence. This also guarantees synchronous movement of the gripper jaws. The virtually backlash-free plain-bearing guide is realised using ground-in gripper jaws.

Flexible range of applications

A wide range of uses:

- Can be used as either a double-acting or single-acting gripper
- Compression spring for supplementary or retaining gripping forces
- Suitable for external and internal gripping
- Centring either via centring pins or centring sleeves

The technology in detail

Gripper closed

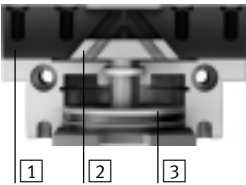

Gripper open



- 1 Gripper jaw
- 2 Wedge with restricted guidance
- 3 Piston with magnet

Additional connections

For sealing air

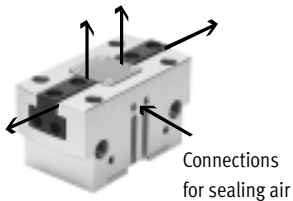

Compressed air flows past the gripper jaw when sealing air (max. 0.5 bar) is connected. This prevents, for example, dust particles from entering the gripper jaw guides.

For lubrication



The connections can also be used for relubricating the guide.

Position sensing/force control

With position transmitter SMAT-8M/SDAT



Analogue positional feedback possible

- Analogue output
 - 0 ... 10 V
 - 4 ... 20 mA

With proportional pressure regulator VPPM



Infinite adjustment of the gripping force possible

- Setpoint input
 - 0 ... 10 V
 - 4 ... 20 mA

With proximity sensor SMT-8G/-10G



Multiple positions can be sensed:

- Open
- Closed
- Workpiece gripped

Parallel grippers HGPT-B, heavy-duty

Key features

Wide range of supply ports

Direct
From the front

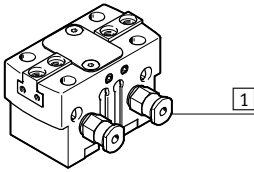

Via adapter plate
From underneath

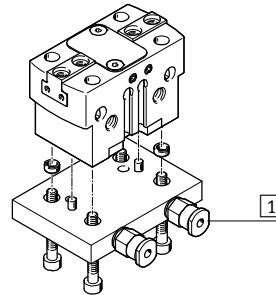

1 Supply ports

Mounting options

Direct mounting
From above

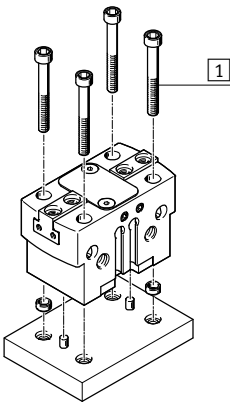

From underneath or from the side

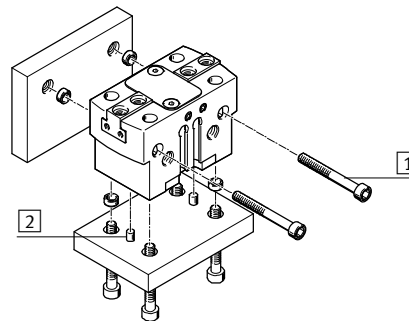

1 Mounting screws
2 Centring pins, centring sleeves

Note

These grippers are not suitable or are of limited suitability for the following application examples:

Not suitable for:

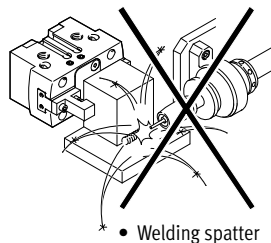

- Welding spatter

Of limited suitability for:

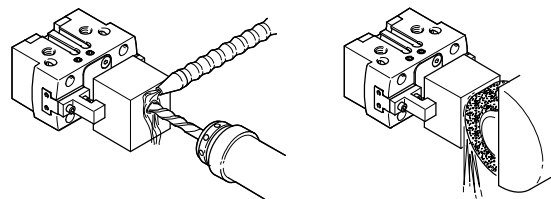

- Machining with sealing air possible
- Aggressive media only possible after consultation with Festo

Parallel grippers HGPT-B, heavy-duty

Key features

FESTO

System product for handling and assembly technology

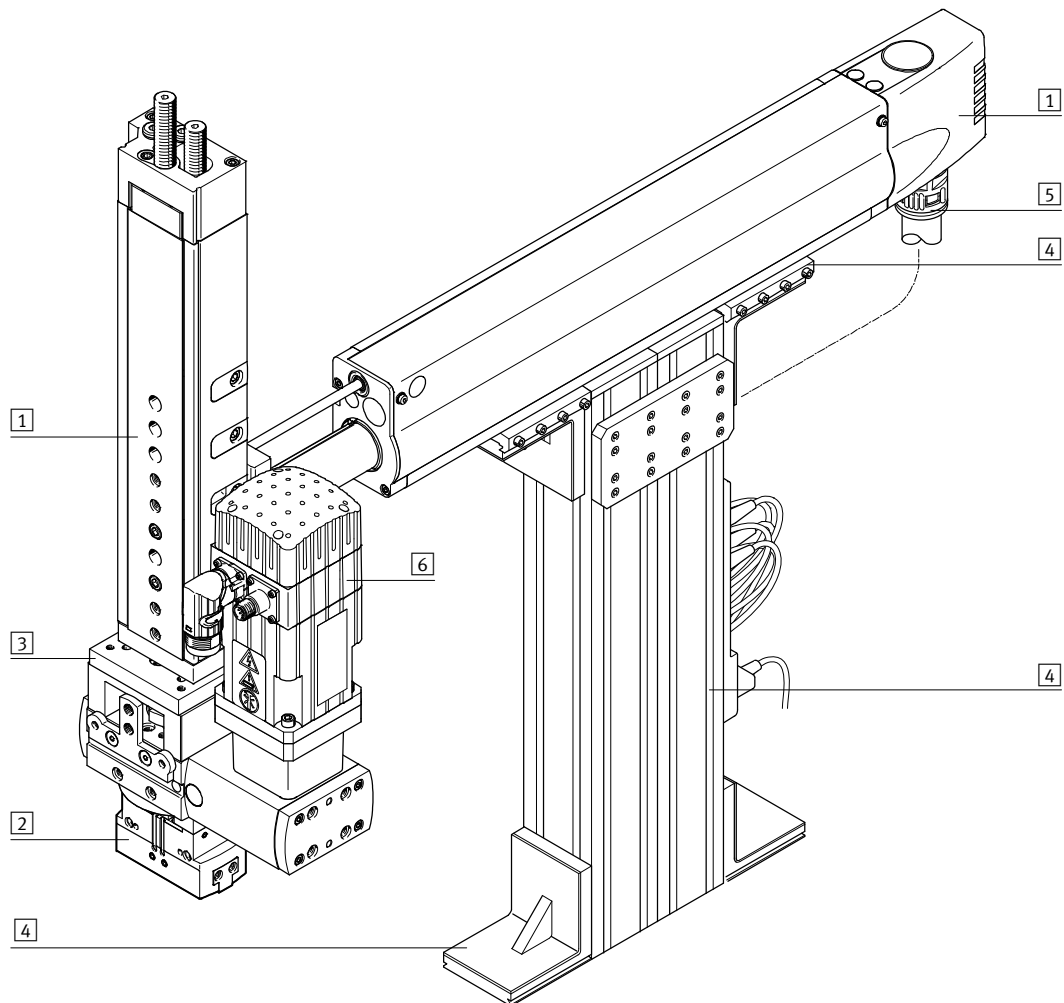

System components and accessories		
	Brief description	→ Page/Internet
1	Drives	Wide range of combinations possible within handling and assembly technology drive
2	Grippers	Wide range of variations possible within handling and assembly technology gripper
3	Adapters	For drive/drive and drive/gripper connections adapter kit
4	Basic components	Profiles and profile connections as well as profile/drive connections basic component
5	Installation components	For a clear, safe layout of electrical cables and tubing installation component
6	Motors	Servo and stepper motors, with or without gearing motor
-	Axes	Wide range of combinations possible within handling and assembly technology axis

Parallel grippers HGPT-B, heavy-duty

Peripherals overview

FESTO

Peripherals overview

System product for handling and assembly technology

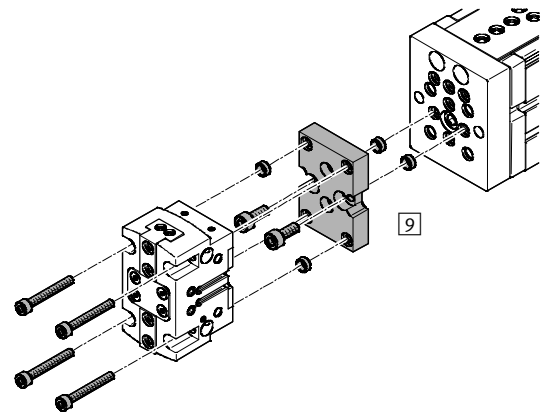
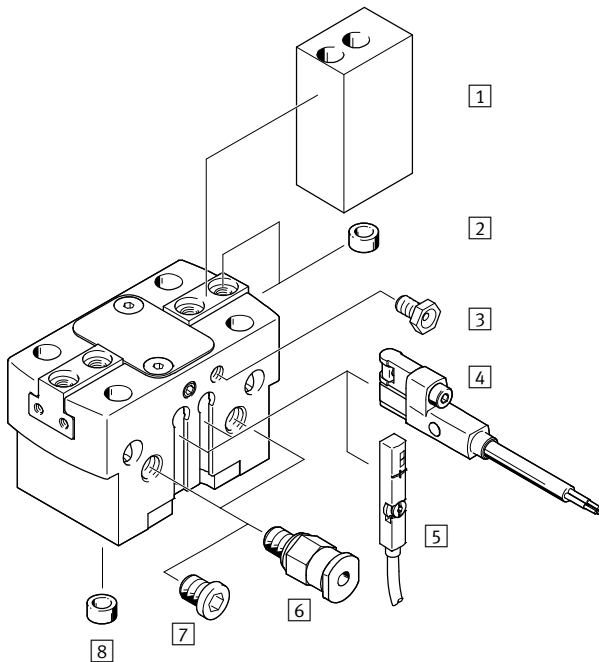

Proportional pressure regulator VPPM

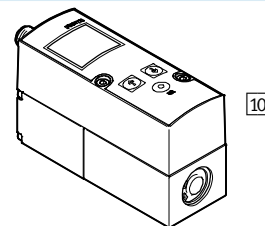

Accessories			
Type	Size	Description	→ Page/Internet
1 Gripper jaw blank BUB-HGPT	16 ... 80	Blank specially matched to the gripper jaws for custom production of gripper fingers	23
2 Centring sleeve ZBH	16 ... 80	<ul style="list-style-type: none"> For centring gripper jaw blanks/gripper fingers on the gripper jaws Centring sleeves are included in the scope of delivery of the gripper 	24
3 Lubrication nipple	16 ... 80	Included in the scope of delivery of the gripper	-
4 Proximity sensor SMT-8G/-10G	16 ... 80	<ul style="list-style-type: none"> For sensing the piston position The proximity sensor is flush with the housing at the bottom 	25
5 Position transmitter SMAT-8M	40 ... 80	<ul style="list-style-type: none"> Continuously senses the position of the piston. It has an analogue output with an output signal that is proportional to the piston position 	25
Position transmitter SDAT	63, 80		
6 Push-in fitting QS	16 ... 80	For connecting compressed air tubing with standard O.D.	qs
7 Blanking plug B	16 ... 80	For sealing the supply ports when using the lower supply ports	24
8 Centring sleeve ZBH	16 ... 80	For centring the gripper during mounting	24
9 Adapter kit DHAA, HAPG	16 ... 80	Drive/gripper connections	19
10 Proportional pressure regulator VPPM	16 ... 80	For infinite adjustment of the gripping force	vppm

Parallel grippers HGPT-B, heavy-duty

Type codes

HGPT – 16 – A – B – F –

Type

HGPT	Parallel gripper
------	------------------

Size

Position sensing

A	Via proximity sensor
---	----------------------

Variant

B	B series
---	----------

Force variant

F	High force
---	------------

Gripping force retention

G1	Opening
G2	Closing

Parallel grippers HGPT-B, heavy-duty

Technical data

Function
Double-acting
HGPT-...

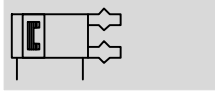

⌀ - Size
16 ... 80 mm

— | - Total stroke
3 ... 50 mm

Function – Variants
Single-acting or
with gripping force retention ...
... opening HGPT-...-G1

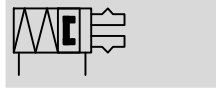

... closing HGPT-...-G2



General technical data										
Size		16	20	25	35	40	50	63	80	
Design	Wedge mechanism Guided motion sequence									
Mode of operation	Double-acting									
Gripper function	Parallel									
Number of gripper jaws	2									
Max. mass per external gripper finger ¹⁾	[g]	40	50	110	180	310	640	1260	1830	
Stroke per gripper jaw	HGPT-...-A	[mm]	3	4	6	8	10	12	16	25
	HGPT-...-A-F	[mm]	1.5	2	3	4	5	6	8	12.5
Pneumatic connection		M5	M5	M5	M5	M5	G1/8	G1/8	G1/4	
Pneumatic connection, sealing air		M3	M3	M5	M5	M5	M5	M5	M5	
Repetition accuracy ²⁾	[mm]	±0.01	±0.02	±0.025						
Max. interchangeability	[mm]	0.2								
Max. operating frequency	[Hz]	3				2				
Rotational symmetry	[mm]	< Ø 0.2								
Position sensing	Via proximity sensor, position transmitter									
Type of mounting	Via through-hole and locating pin/centring sleeve									
	Via female thread and locating pin/centring sleeve									
Mounting position	Any									

1) Valid for unthrottled operation

2) End-position drift under constant conditions of use with 100 consecutive strokes in the direction of movement of the gripper jaws

- | - Note: This product conforms to ISO 1179-1 and to ISO 228-1

Operating and environmental conditions			
Min. operating pressure	HGPT-...-A	[bar]	3
	HGPT-...-A-G	[bar]	4
Max. operating pressure		[bar]	8
Operating pressure, sealing air		[bar]	0 ... 0.5
Operating medium	Compressed air in accordance with ISO 8573-1:2010 [7:4:4]		
Note on operating/pilot medium	Operation with lubricated medium possible (in which case lubricated operation will always be required)		
Ambient temperature ¹⁾		[°C]	+5 ... +60
Protection type	IP40		
Corrosion resistance class CRC ²⁾	2		

1) Note operating range of proximity sensors.

2) Corrosion resistance class CRC 2 to Festo standard FN 940070

Moderate corrosion stress. Indoor applications in which condensation may occur. External visible parts with primarily decorative requirements for the surface and which are in direct contact with the ambient atmosphere typical for industrial applications.

Parallel grippers HGPT-B, heavy-duty

Technical data

Weight [g]								
Size	16	20	25	35	40	50	63	80
HGPT-...-A	85	135	266	490	821	1400	2712	4745
HGPT-...-A-F	85	135	266	490	821	1400	2712	4745
HGPT-...-A-G	100	155	353	567	1075	1832	3562	6287

Materials

Sectional view

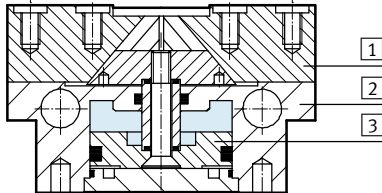

Parallel gripper		
1	Gripper jaw	Hardened steel
2	Housing	Hard anodised wrought aluminium alloy
3	Piston	Hard anodised aluminium
-	Seals	Nitrile rubber
-	Note on materials	Free of copper and PTFE RoHS-compliant

Gripping force [N] at 6 bar

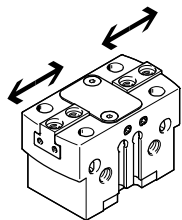

Size		16	20	25	35	40	50	63	80
Gripping force per gripper jaw									
HGPT-...-A	Opening	60	82	133	245	355	570	896	1613
	Closing	53	77	124	229	331	535	851	1551
HGPT-...-A-F	Opening	108	172	238	500	723	1185	1885	3275
	Closing	96	161	221	467	674	1113	1791	3150
Total gripping force									
HGPT-...-A	Opening	120	162	266	490	710	1140	1792	3226
	Closing	106	154	248	458	662	1070	1702	3102
HGPT-...-A-F	Opening	216	344	476	1000	1446	2370	3770	6550
	Closing	192	322	442	934	1328	2226	3522	6300

Parallel grippers HGPT-B, heavy-duty

Technical data

Characteristic load values at the gripper jaws

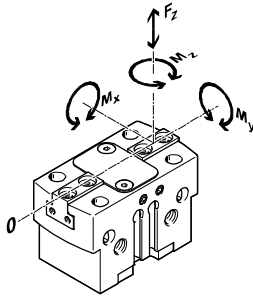

The indicated permissible forces and torques apply to a single gripper jaw. They include the lever arm, additional applied loads due to the workpiece or gripper fingers and acceleration

forces occurring during movement. The zero co-ordinate line (gripper jaw guide) must be taken into consideration for the calculation of torques.

Size		16	20	25	35	40	50	63	80
Max. permissible force F_z	[N]	200	700	1200	1800	2500	3200	5000	7000
Max. permissible torque M_x	[Nm]	10	15	50	80	100	120	160	180
Max. permissible torque M_y	[Nm]	12	15	45	60	90	120	180	220
Max. permissible torque M_z	[Nm]	6	8	35	50	75	100	140	170

Mass moment of inertia [$\text{kgm}^2 \times 10^{-4}$]

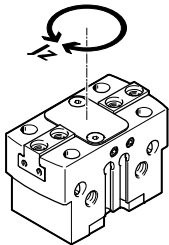

Mass moment of inertia of the parallel gripper in relation to the central axis, without external gripper fingers, without load.

Size		16	20	25	35	40	50	63	80
HGPT-...-A		0.141	0.344	0.983	2.807	7.277	19.488	60.903	150.515
HGPT-...-A-G		0.163	0.445	1.479	3.974	10.990	29.423	93.034	238.336

Gripper jaw backlash

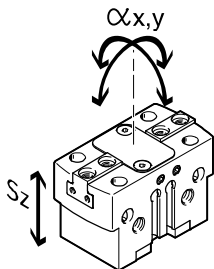

With grippers, backlash occurs between the gripper jaws and the housing due to the plain-bearing guide. The backlash values listed in the table have been calculated based on the traditional accumulative tolerance method.

Size		16	20	25	35	40	50	63	80
Max. gripper jaw backlash S_z	[mm]	0.02							
Max. gripper jaw angular backlash α_x, α_y	[°]	0.1							

Parallel grippers HGPT-B, heavy-duty

Technical data



Opening and closing times [ms] at 6 bar

Without external gripper fingers

With external gripper fingers

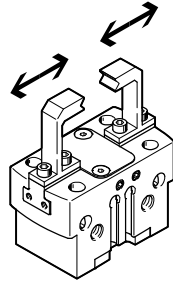
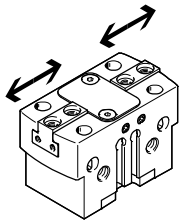

The indicated opening and closing times [ms] have been measured at room temperature at an operating pressure of 6 bar with horizontally mounted gripper without additional

gripper fingers. The grippers must be throttled for greater loads [g]. Opening and closing times must then be adjusted accordingly.

Size			16	20	25	35	40	50	63	80
Without external gripper fingers										
Standard	HGPT-...-A	Opening	9	22	26	36	56	80	150	214
		Closing	11	30	32	67	60	85	156	213
	HGPT-...-A-G1	Opening	13	13	24	37	67	70	146	182
		Closing	31	25	48	114	135	153	328	353
	HGPT-...-A-G2	Opening	22	35	40	69	122	151	294	379
		Closing	15	18	28	87	71	77	185	176
High force	HGPT-...-A-F	Opening	8	28	25	33	60	83	143	212
		Closing	10	31	32	70	64	82	152	211
	HGPT-...-A-F-G1	Opening	19	13	24	35	71	70	145	180
		Closing	30	25	45	115	143	143	315	340
	HGPT-...-A-F-G2	Opening	33	38	36	63	120	137	308	362
		Closing	17	14	28	72	72	80	154	178
With external gripper fingers (as a function of the load per gripper finger)										
HGPT-...	50 g	10	-	-	-	-	-	-	-	-
	100 g	15	30	-	-	-	-	-	-	-
	200 g	21	42	35	-	-	-	-	-	-
	300 g	-	52	42	42	-	-	-	-	-
	400 g	-	-	49	49	63	-	-	-	-
	500 g	-	-	-	55	71	-	-	-	-
	600 g	-	-	-	-	78	-	-	-	-
	800 g	-	-	-	-	90	90	-	-	-
	1000 g	-	-	-	-	-	95	-	-	-
	1200 g	-	-	-	-	-	100	-	-	-
	1500 g	-	-	-	-	-	-	-	164	-
	1800 g	-	-	-	-	-	-	-	179	-
	2000 g	-	-	-	-	-	-	-	189	223
	2200 g	-	-	-	-	-	-	-	-	234
	2400 g	-	-	-	-	-	-	-	-	244

Parallel grippers HGPT-B, heavy-duty

Technical data

Gripping force F_H per gripper jaw as a function of operating pressure and lever arm x

The gripping forces as a function of operating pressure and lever arm can be determined from the following graphs.

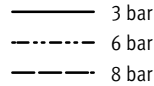
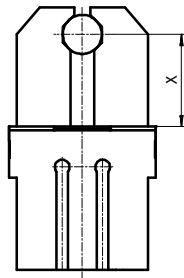

Note
Gripper selection sizing software
→ www.festo.com

External gripping (closing)

Standard

HGPT-16-A

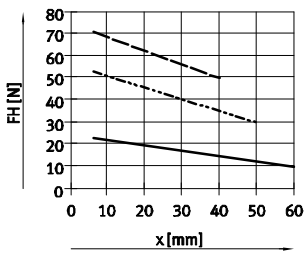

HGPT-20-A

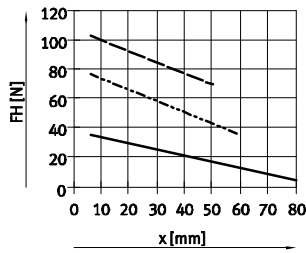

HGPT-25-A

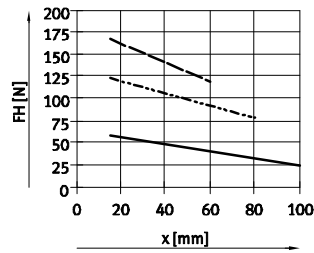

HGPT-35-A

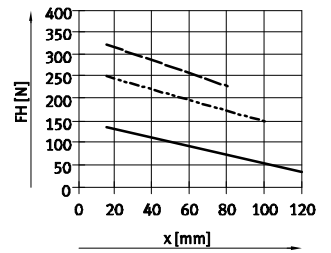

HGPT-40-A

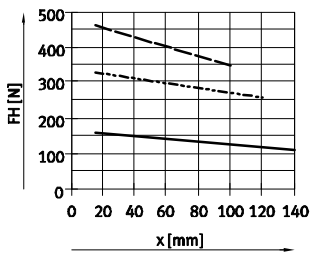

HGPT-50-A

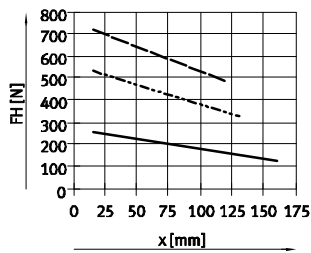

HGPT-63-A

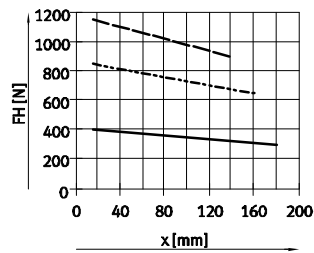

HGPT-80-A

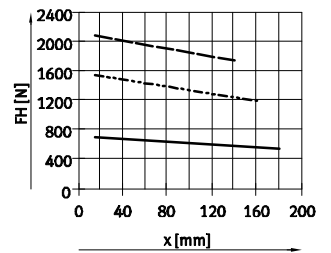

High force

HGPT-16-A-F

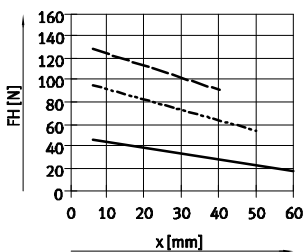

HGPT-20-A-F

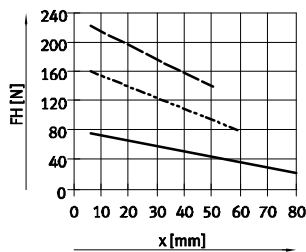

HGPT-25-A-F

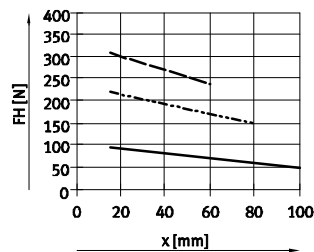

HGPT-35-A-F

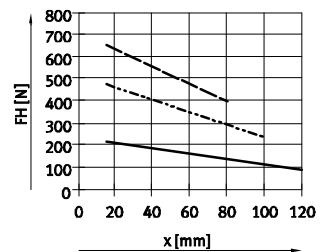

HGPT-40-A-F

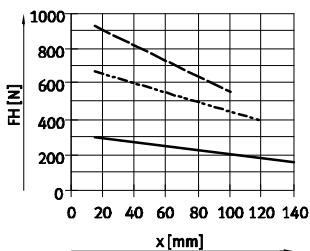

HGPT-50-A-F

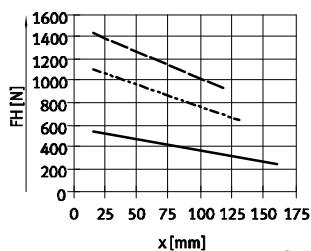

HGPT-63-A-F

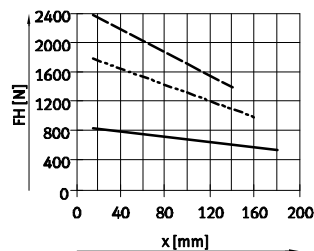

HGPT-80-A-F

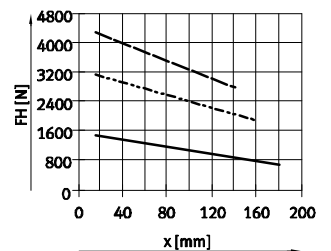

Parallel grippers HGPT-B, heavy-duty

Technical data

Gripping force F_H per gripper jaw as a function of operating pressure and lever arm x

The gripping forces as a function of operating pressure and lever arm can be determined from the following graphs.

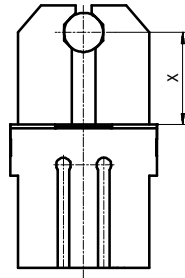

- 3 bar
- - - 6 bar
- · - 8 bar

Note
Gripper selection
sizing software
→ www.festo.com

Internal gripping (opening)

Standard

HGPT-16-A

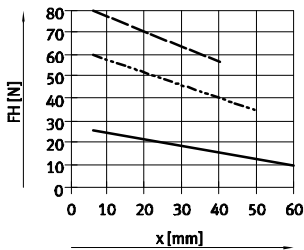

HGPT-20-A

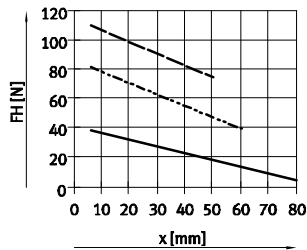

HGPT-25-A

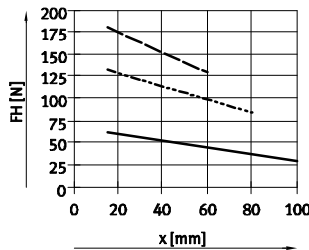

HGPT-35-A

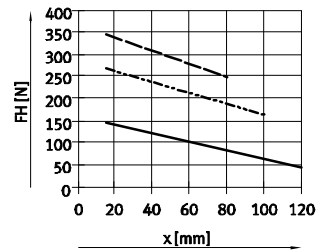

HGPT-40-A

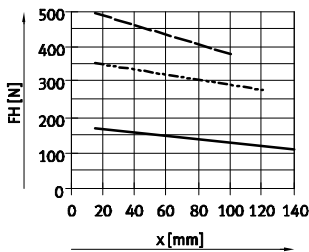

HGPT-50-A

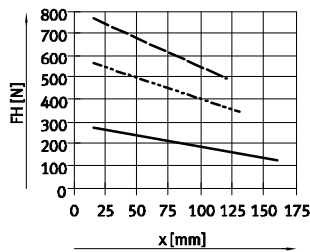

HGPT-63-A

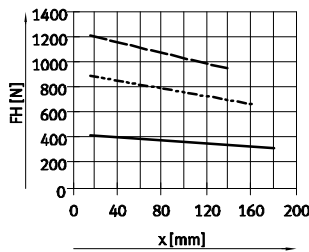

HGPT-80-A

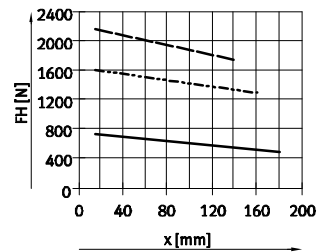

High force

HGPT-16-A-F

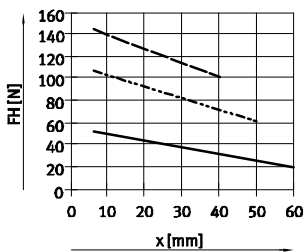

HGPT-20-A-F

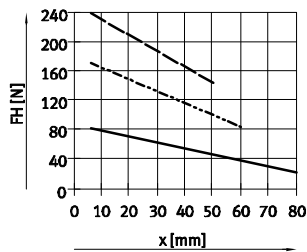

HGPT-25-A-F

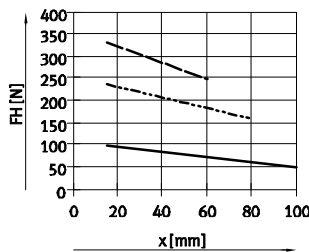

HGPT-35-A-F

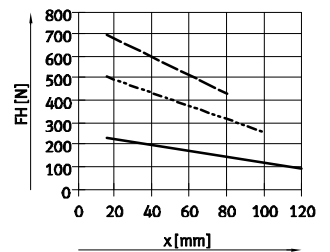

HGPT-40-A-F

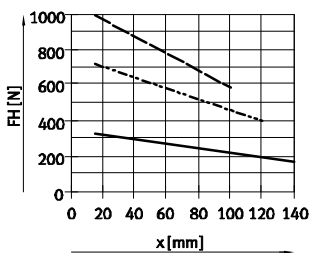

HGPT-50-A-F

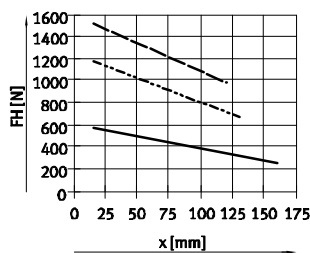

HGPT-63-A-F

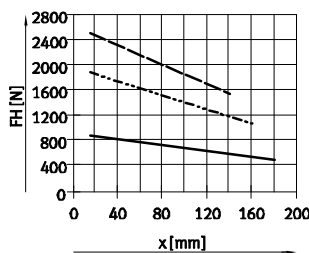

HGPT-80-A-F

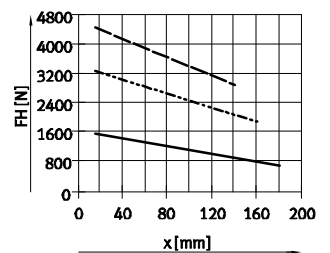

Parallel grippers HGPT-B, heavy-duty

Technical data

Gripping force F_H per gripper jaw at 6 bar as a function of lever arm x and eccentricity a and b

The following formula must be used to calculate the lever arm x with eccentric gripping:

$$x = \sqrt{a^2 + b^2}$$

The gripping force F_H can then be read from the graphs (→ from page 11) using the calculated value x .

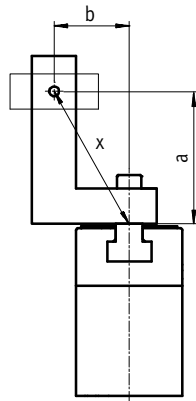

Calculation example

Given:

Distance $a = 45$ mm

Distance $b = 40$ mm

To be calculated:

The gripping force at 6 bar, with an HGPT-25, used as an external gripper

Procedure:

Calculate the lever arm x

$$x = \sqrt{45^2 + 40^2}$$

$x = 60$ mm

The graph (→ page 11) gives a value of $F_H = 89$ N for the gripping force.

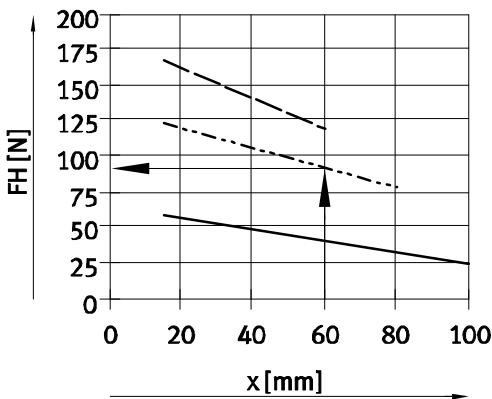

Parallel grippers HGPT-B, heavy-duty

Technical data

Spring force F_F as a function of size, gripper jaw stroke l

Gripping force retention for HGPT-...-G...

The spring forces F_F as a function of gripper jaw stroke l can be determined from the following graph.

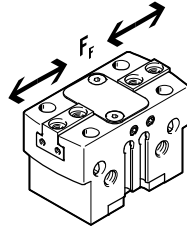

Standard

HGPT-...-A-G

Size 16 ... 35

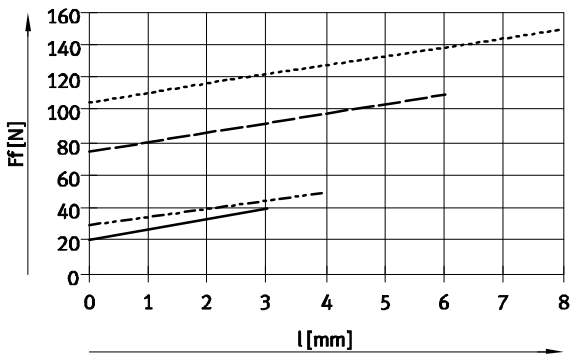

- HGPT-16-A-G
- - - HGPT-20-A-G
- - - - HGPT-25-A-G
- HGPT-35-A-G

High force

HGPT-...-A-F-G

Size 16 ... 35

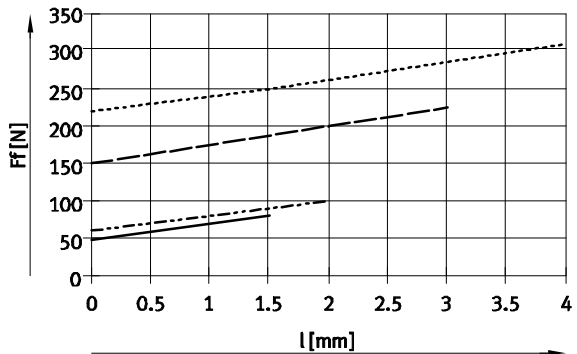

- HGPT-16-A-F-G
- - - HGPT-20-A-F-G
- - - - HGPT-25-A-F-G
- HGPT-35-A-F-G

Size 40 ... 80

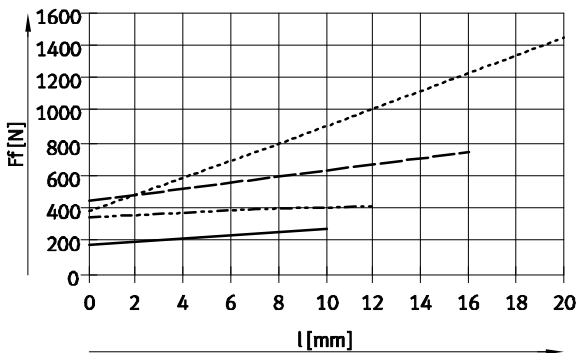

- HGPT-40-A-G
- - - HGPT-50-A-G
- - - - HGPT-63-A-G
- HGPT-80-A-G

Size 40 ... 80

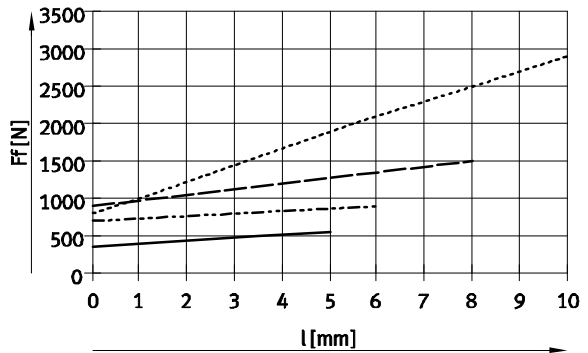

- HGPT-40-A-F-G
- - - HGPT-50-A-F-G
- - - - HGPT-63-A-F-G
- HGPT-80-A-F-G

Parallel grippers HGPT-B, heavy-duty

Technical data

FESTO

Spring force F_F as a function of size, gripper jaw stroke l and lever arm x per gripper finger

The lever arm x must be taken into consideration when determining the actual spring force F_{Ftotal} .

The formulae for calculating the spring force are provided in the table below.

Standard – HGPT-...-A-G

Gripping force retention	Size	$F_{Ftotal} =$
G1	16	$-0.1 * x + 0.7 * F_F$
	20	$-0.05 * x + 0.9 * F_F$
	25	$-0.7 * x + 0.7 * F_F$
	35	$-0.65 * x + 0.7 * F_F$
	40	$-1.05 * x + 0.8 * F_F$
	50	$-0.75 * x + 0.8 * F_F$
	63	$-2 * x + 0.8 * F_F$
	80	$-1.4 * x + 0.6 * F_F$

Gripping force retention	Size	$F_{Ftotal} =$
G2	16	$-0.2 * x + 0.7 * F_F$
	20	$-0.65 * x + 0.9 * F_F$
	25	$-0.55 * x + 0.7 * F_F$
	35	$-0.05 * x + 0.7 * F_F$
	40	$-1.05 * x + 0.8 * F_F$
	50	$-1.4 * x + 0.8 * F_F$
	63	$-1.2 * x + 0.8 * F_F$
	80	$-0.6 * x + 0.6 * F_F$

High force – HGPT-...-A-F-G

Gripping force retention	Size	$F_{Ftotal} =$
G1	16	$-0.6 * x + 0.6 * F_F$
	20	$-0.7 * x + 0.75 * F_F$
	25	$-0.85 * x + 0.9 * F_F$
	35	$-0.4 * x + 0.55 * F_F$
	40	$-1.9 * x + 0.75 * F_F$
	50	$-2.5 * x + 0.7 * F_F$
	63	$-5.5 * x + 0.7 * F_F$
	80	$-5.65 * x + 0.8 * F_F$

Gripping force retention	Size	$F_{Ftotal} =$
G2	16	$-0.4 * x + 0.6 * F_F$
	20	$-0.95 * x + 0.75 * F_F$
	25	$-0.5 * x + 0.9 * F_F$
	35	$-0.4 * x + 0.55 * F_F$
	40	$-2.3 * x + 0.75 * F_F$
	50	$-1 * x + 0.7 * F_F$
	63	$-1 * x + 0.7 * F_F$
	80	$-0.5 * x + 0.8 * F_F$

Determination of the actual gripping forces F_{Gr} for HGPT-...-G1 and HGPT-...-G2 as a function of the application

The parallel grippers with integrated spring type HGPT-...-G1 (opening gripping force retention) and HGPT-...-G2 (closing gripping force retention) can be used as:

- single-acting grippers

- grippers with supplementary gripping force and
- grippers with gripping force retention depending on requirements.

In order to calculate available gripping forces F_{Gr} (per gripper jaw), the gripping force (F_H) and spring force (F_{Ftotal}) must be combined accordingly.

Application

Single-acting

- Gripping with spring force:
 $F_{Gr} = F_{Ftotal}$
- Gripping with pressure force:
 $F_{Gr} = F_H - F_{Ftotal}$

Supplementary gripping force

- Gripping with pressure and spring force:
 $F_{Gr} = F_H + F_{Ftotal}$

Gripping force retention

- Gripping with spring force:
 $F_{Gr} = F_{Ftotal}$

Parallel grippers HGPT-B, heavy-duty

Technical data

FESTO

Dimensions

Download CAD data → www.festo.com

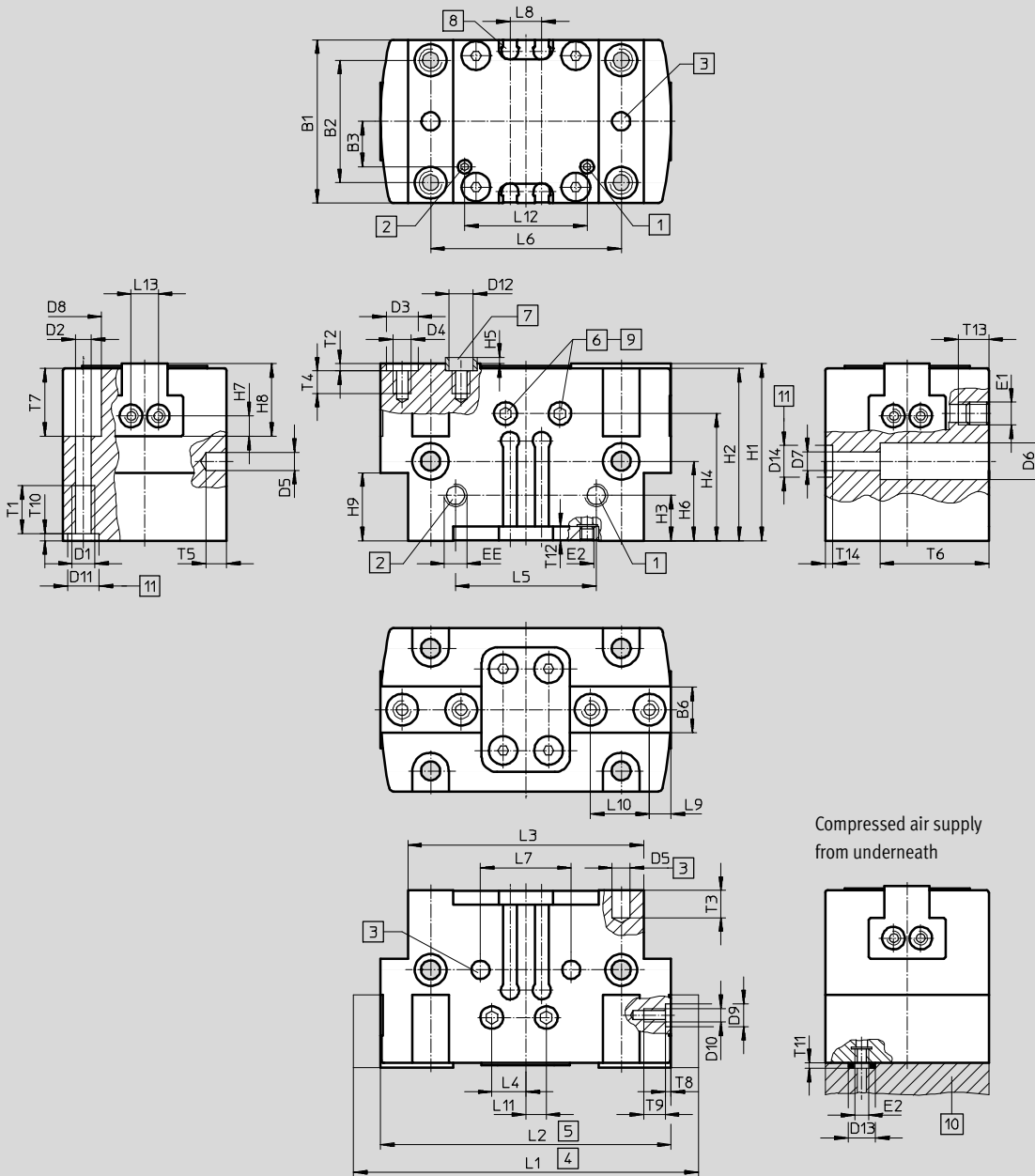

- 1 Supply port opening, either on the side or underneath (bottom port sealed on delivery)
- 2 Supply port closing, either on the side or underneath (bottom port sealed on delivery)

- 3 Hole for dowel pin (not included in the scope of delivery)
- 4 Gripper jaw open
- 5 Gripper jaw closed
- 6 Sealing air port (sealed on delivery)
- 7 Centring sleeves ZBH (4 included in the scope of delivery)

- 8 Slot for proximity sensor
- 9 Lubrication nipple (sealed on delivery)
- 10 O-ring for parallel gripper HGPT-16 ... 40: \varnothing 3x1.5 HGPT-50 ... 80: \varnothing 5x1.5
- 11 Hole for centring sleeve ZBH

Compressed air supply from underneath

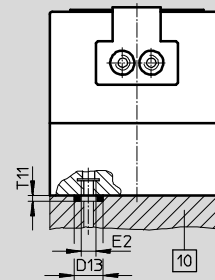

Parallel grippers HGPT-B, heavy-duty

Technical data

Size [mm]	B1 ±0.05	B2 ¹⁾	B3 ±0.1	B6 -0.05 -0.1	D1	D2 ∅	D3 ∅ H8/h7	D4	D5 ∅ H8	D6 ∅ ±0.1	D7 ∅	D8 ∅ +0.3	D9 ∅ H8	D10	D11 ∅ H8	D12 ∅
16	24	17	4	6	M3	2.6	5	M3	2	4.6	2.6	4.6	-	M2	5	3.2
20 ²⁾	28	22	8.7	6.5	M4	3.3	5	M3	3	6	3.2	6	5	M3	5	3.2
25	36	27	11	10	M5	4.2	7	M4	4	8	4.2	8	5	M3	7	5.3
35	42	32	13	12	M5	4.2	9	M5	4	9.2	5.3	8	7	M5	7	6.4
40	50	38	17	14	M6	5.1	9	M6	5	11	6.4	9	7	M5	9	6.4
50	60	45	20	15.5	M8	6.8	9	M6	6	13.5	8.4	11	7	M5	12	6.4
63	72	56	24.5	20	M8	6.8	12	M10	6	13.5	8.4	11	7	M5	12	10.3
80	100	70	39.5	22	M10	8.5	15	M12	8	16.5	10.2	13.5	9	M6	12	12.4

Size [mm]	D13 ∅	D14 ∅ H8/h7	EE	E1	E2	H1		H2		H3		H4		H5 -0.3	H6 ¹⁾	
						±0.05	-G ±0.05	±0.05	-G ±0.05	±0.1	-G ±0.1		-G			-G
16	6	-	M5	M3	M3	29	37	28	36	12	12	23.7	31.7	1.2	17.5	25.5
20	6	-	M5	M3	M3	31	38	30	37	10	15	23	30	1.2	14.5	21.5
25	6	7	M5	M5	M3	39	57	38	56	10	20	28	46	1.4	17.5	35.5
35	6	7	M5	M5	M3	49	67	48	66	12	30	36	54	1.9	20	38
40	6	9	M5	M5	M3	55	81	54	80	15	36	41	67	1.9	25	51
50	8	12	G1/8	M5	M5	63	93	62	92	15	30	47	77	1.9	30	60
63	8	12	G1/8	M5	M5	77	117	76	116	18	26	56	96	2.4	28	68
80	8	12	G1/4	M5	M5	91	133	90	132	22	33	65	107	2.9	34	76

Size [mm]	H7 ¹⁾	H8 -0.02	H9		L1		L2 ±0.5	L3 ±0.1	L4 ±0.5	L5 ±0.1	L6 ¹⁾	L7 ¹⁾	L8 +0.1	L9 ¹⁾	L10 ¹⁾	L11 ±0.5
			±0.1	-G ±0.1	±0.5	-F ±0.5										
16	2.25	8.5	15	23	50	47	44	36	5.5	20	29	20	6	3	8	1
20	3	12	15	22	64	60	56	44	2.5	24	35	24	6	3.25	12	2.5
25	4.5	16	15	33	76	70	64	52	3.5	31	42	20	7	4.75	13	3.5
35	5.5	19	20	38	96	88	80	64	5.5	40	52	40	7	5.5	16	5.5
40	5.5	22	24	50	120	110	100	80	5.5	49	66	50	10	6.5	20	5.5
50	7.5	25.5	26	56	149	137	125	100	5.5	63	82	60	10	8	24	5.5
63	9	32	32	72	192	176	160	125	5.5	74	100	76	10	9.5	32	5.5
80	11	39	34	77	230	205	180	154	5.5	82	130	100	10	12	40	5.5

Size [mm]	L12 ±0.1	L13 ¹⁾	T1 min.	T2 +0.1	T3 min.	T4 min.	T5 min.	T6	T7		T8 +0.1	T9	T10 +0.1	T11	T12 min.	T13 min.	T14 +0.1
									+0.2	-G +0.2							
16	22	6	5.5	1.3	4	5	4	15	14	22	-	3	1.3	1.2	3	5.5	-
20	22.6	6	6.5	1.3	5	5.5	4	19	11	11	1.3	6	1.3	1.2	3	5.5	-
25	29	6	8.5	1.6	6	6.5	4.5	24	15	15	1.3	6	1.6	1.2	3	6.7	1.6
35	39	13	8.5	2.1	6	8.5	4.5	16	19	19	1.6	9	1.6	1.2	3	6.5	1.6
40	47.4	13	10.5	2.1	6	10.5	6	33	20	20	1.6	9	2.1	1.2	4	6.5	2.1
50	61	13	12.5	2.1	8	10.5	6	43	23	23	1.6	9	2.6	1.2	4	6.5	2.6
63	75	13	12.5	2.6	8	15.5	7	55	35	35	1.6	9	2.6	1.2	5	6.5	2.6
80	82	20	15	3.1	10	20	10	70	44	44	2.1	10	2.6	1.2	5.5	5	2.6

- 1) Tolerance for centring hole ±0.02 mm
Tolerance for thread ±0.1 mm
- 2) Dowel pins [3] must be used when mounted from below.
- ||- Note: This product conforms to ISO 1179-1 and to ISO 228-1

Parallel grippers HGPT-B, heavy-duty

Technical data

Ordering data						
Size [mm]	Double-acting without compression spring		Single-acting or with gripping force retention			
	Part No.	Type	Opening		Closing	
	Part No.	Type	Part No.	Type	Part No.	Type
Standard						
16	560192	HGPT-16-A-B	560193	HGPT-16-A-B-G1	560194	HGPT-16-A-B-G2
20	560198	HGPT-20-A-B	560199	HGPT-20-A-B-G1	560200	HGPT-20-A-B-G2
25	560204	HGPT-25-A-B	560205	HGPT-25-A-B-G1	560206	HGPT-25-A-B-G2
35	560210	HGPT-35-A-B	560211	HGPT-35-A-B-G1	560212	HGPT-35-A-B-G2
40	560216	HGPT-40-A-B	560217	HGPT-40-A-B-G1	560218	HGPT-40-A-B-G2
50	560222	HGPT-50-A-B	560223	HGPT-50-A-B-G1	560224	HGPT-50-A-B-G2
63	560228	HGPT-63-A-B	560229	HGPT-63-A-B-G1	560230	HGPT-63-A-B-G2
80	560234	HGPT-80-A-B	560235	HGPT-80-A-B-G1	560236	HGPT-80-A-B-G2
High force						
16	560195	HGPT-16-A-B-F	560196	HGPT-16-A-B-F-G1	560197	HGPT-16-A-B-F-G2
20	560201	HGPT-20-A-B-F	560202	HGPT-20-A-B-F-G1	560203	HGPT-20-A-B-F-G2
25	560207	HGPT-25-A-B-F	560208	HGPT-25-A-B-F-G1	560209	HGPT-25-A-B-F-G2
35	560213	HGPT-35-A-B-F	560214	HGPT-35-A-B-F-G1	560215	HGPT-35-A-B-F-G2
40	560219	HGPT-40-A-B-F	560220	HGPT-40-A-B-F-G1	560221	HGPT-40-A-B-F-G2
50	560225	HGPT-50-A-B-F	560226	HGPT-50-A-B-F-G1	560227	HGPT-50-A-B-F-G2
63	560231	HGPT-63-A-B-F	560232	HGPT-63-A-B-F-G1	560233	HGPT-63-A-B-F-G2
80	560237	HGPT-80-A-B-F	560238	HGPT-80-A-B-F-G1	560239	HGPT-80-A-B-F-G2

Parallel grippers HGPT-B, heavy-duty



Accessories

FESTO

Adapter kit
DHAA, HAPG

Material:
Wrought aluminium alloy
Free of copper and PTFE
RoHS-compliant

 Note
The kit includes the individual mounting interface as well as the necessary mounting material.

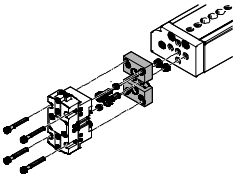
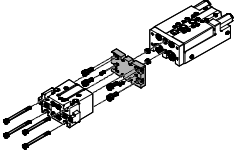
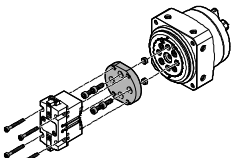
Permissible drive/gripper combinations with adapter kit					Download CAD data → www.festo.com		
Combination	Drive Size	Gripper Size	Mounting option		Adapter kit		
					CRC ¹⁾	Part No.	Type
	DGSL	HGPT-B			DHAA, HAPG		
	8, 10	16, 20	■	■	2	564957	DHAA-G-G6-8-B8-16
	12, 16	16, 20	■	■		564954	DHAA-G-G6-16-B8-16
	12, 16	25	■	■		564952	DHAA-G-G6-16-B8-25
	20, 25	25, 35	■	■		537175	HAPG-79
	20, 25	40	■	■		564951	DHAA-G-G6-20-B8-40
	SLT	HGPT-B			DHAA, HAPG		
	6	16	■	–	2	537168	HAPG-74
	10	16, 20	■	–		564957	DHAA-G-G6-8-B8-16
	16	16, 20	■	–		564954	DHAA-G-G6-16-B8-16
	16	25	■	–		564952	DHAA-G-G6-16-B8-25
	20	25, 35	■	–		537175	HAPG-79
	25	35	■	–		564953	DHAA-G-H2-20-B8-35
	25	40	■	–		564951	DHAA-G-G6-20-B8-40
	DSM-...-HD	HGPT-B			DHAA		
	12	16	■	■	2	8079169	DHAA-G-R3-12-B8-16
	12	20	■	■		8079170	DHAA-G-R3-12-B8-20
	16	16	■	■		8079193	DHAA-G-R3-16-B8-16
	16	20	■	■		8079195	DHAA-G-R3-16-B8-20
	25	16	■	■		8079202	DHAA-G-R3-25-B8-16
	25	20	■	■		8079205	DHAA-G-R3-25-B8-20
	25	25	■	■		8079207	DHAA-G-R3-25-B8-25
	32	20	■	■		8079217	DHAA-G-R3-32-B8-20
	32	25	■	■		8079218	DHAA-G-R3-32-B8-25
	32	35	■	■		8079221	DHAA-G-R3-32-B8-35

1) Corrosion resistance class CRC 2 to Festo standard FN 940070

Moderate corrosion stress. Indoor applications in which condensation may occur. External visible parts with primarily decorative requirements for the surface and which are in direct contact with the ambient atmosphere typical for industrial applications.

Parallel grippers HGPT-B, heavy-duty



Accessories



**Adapter kit
DHAA**

Material:
Wrought aluminium alloy
Free of copper and PTFE
RoHS-compliant

 Note
The kit includes the individual mounting interface as well as the necessary mounting material.

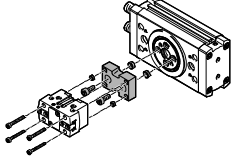
Permissible drive/gripper combinations with adapter kit					Download CAD data → www.festo.com		
Combination	Drive Size	Gripper Size	Mounting option		Adapter kit		
					CRC ¹⁾	Part No. Type	
	DRRD/HGPT-B	DRRD	HGPT-B		DHAA		
	12	16	■	■	2	2449927 DHAA-G-Q11-12-B8/B8G-16	
	12	20	■	■		2449921 DHAA-G-Q11-12-B8-20	
	16	16	■	■		2091740 DHAA-G-Q11-16-B8/B8G-16	
	16	20	■	■		2091577 DHAA-G-Q11-16-B8-20	
	16	25	■	■		2090543 DHAA-G-Q11-16-B8-25	
	20	25	■	■		2088114 DHAA-G-Q11-20-B8-25	
	20	35	■	■		2087524 DHAA-G-Q11-20-B8-35	
	25	35	■	■		1731604 DHAA-G-Q11-25-B8-35	
	25	40	■	■		1731735 DHAA-G-Q11-25-B8-40	
	32	40	■	■		2092070 DHAA-G-Q11-32-B8-40	
	35	40	■	■		2114241 DHAA-G-Q11-35-B8-40	
	32	50	■	■		2118750 DHAA-G-Q11-32-B8-50	
	35, 40	50	■	■		2124990 DHAA-G-Q11-35/40-B8-50	
	40	63	■	■		2125264 DHAA-G-Q11-40-B8-63	
	50	63	■	■		2424526 DHAA-G-Q11-50-B8-63	
	50	80	■	■		2424527 DHAA-G-Q11-50-B8-80	
	DRRD		HGPT-B-G			DHAA	
	12	16	■	■	2	2449927 DHAA-G-Q11-12-B8/B8G-16	
	12	20	■	■		2800827 DHAA-G-Q11-12-B8G-20	
	16	16	■	■		2091740 DHAA-G-Q11-16-B8/B8G-16	
	16	20	■	■		2595935 DHAA-G-Q11-16-B8G-20	
	16	25	■	■		2596187 DHAA-G-Q11-16-B8G-25	
	20	25	■	■		2596248 DHAA-G-Q11-20-B8G-25	
	20	35	■	■		2596517 DHAA-G-Q11-20-B8G-35	
	25	35	■	■		2597040 DHAA-G-Q11-25-B8G-35	
	25	40	■	■		2597322 DHAA-G-Q11-25-B8G-40	
	32	40	■	■		2597387 DHAA-G-Q11-32-B8G-40	
	35	40	■	■		2597928 DHAA-G-Q11-35-B8G-40	
	32	50	■	■		2597428 DHAA-G-Q11-32-B8G-50	
	35, 40	50	■	■		2604977 DHAA-G-Q11-35/40-B8G-50	
	40	63	■	■		2604813 DHAA-G-Q11-40-B8G-63	
50	63	■	■	2604845 DHAA-G-Q11-50-B8G-63			
50	80	■	■	2604887 DHAA-G-Q11-50-B8G-80			

1) Corrosion resistance class CRC 2 to Festo standard FN 940070
Moderate corrosion stress. Indoor applications in which condensation may occur. External visible parts with primarily decorative requirements for the surface and which are in direct contact with the ambient atmosphere typical for industrial applications.

Parallel grippers HGPT-B, heavy-duty

Accessories



Adapter kit
DHAA, HAPG

Material:
Wrought aluminium alloy
Free of copper and PTFE
RoHS-compliant

 Note
The kit includes the individual mounting interface as well as the necessary mounting material.

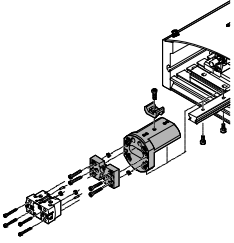
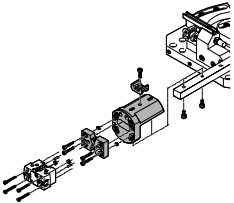
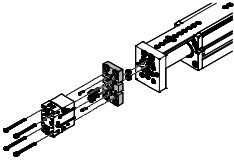
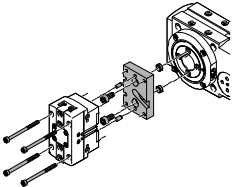
Permissible drive/gripper combinations with adapter kit						Download CAD data → www.festo.com	
Combination	Drive	Gripper	Mounting option		Adapter kit		
			Size	Size	CRC ¹⁾	Part No.	Type
	HSP	HGPT-B			DHAA, HAPG		
	12	16	■	–	2	564957	DHAA-G-G6-8-B8-16
						540881	HAPG-70-B
	16	16, 20	■	–		564957	DHAA-G-G6-8-B8-16
				540882	HAPG-71-B		
	25	16, 20	■	–	564957	DHAA-G-G6-8-B8-16	
					540883	HAPG-72-B	
	HSW	HGPT-B			DHAA, HAPG		
	12	16	■	–	2	564957	DHAA-G-G6-8-B8-16
						540882	HAPG-71-B
	16	16, 20	■	–	564957	DHAA-G-G6-8-B8-16	
				540882	HAPG-71-B		
	EGSL	HGPT-B			DHAA, HAPG		
	45, 55	25	■	■	2	564952	DHAA-G-G6-16-B8-25
	75	40	■	■		564951	DHAA-G-G6-20-B8-40
	75	25, 35	■	■		537175	HAPG-79
	ERMB	HGPT-B			DHAA, HAPG		
	20	25	■	■	2	537181	HAPG-SD2-25
	20, 25	35	■	■		537173	HAPG-SD2-23
	25, 32	40	■	■		537184	HAPG-SD2-26
	32	50	■	■		564956	DHAA-G-Q5-32-B8-50

1) Corrosion resistance class CRC 2 to Festo standard FN 940070
Moderate corrosion stress. Indoor applications in which condensation may occur. External visible parts with primarily decorative requirements for the surface and which are in direct contact with the ambient atmosphere typical for industrial applications.

Parallel grippers HGPT-B, heavy-duty



Accessories



Adapter kit
DHAA, HAPG

Material:
Wrought aluminium alloy
Free of copper and PTFE
RoHS-compliant

 Note
The kit includes the individual mounting interface as well as the necessary mounting material.

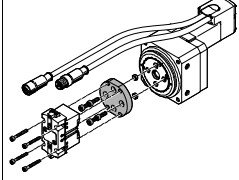
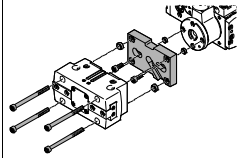
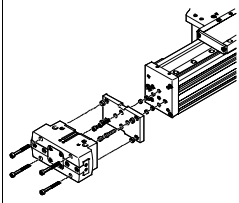
Permissible drive/gripper combinations with adapter kit					Download CAD data → www.festo.com		
Combination	Drive Size	Gripper Size	Mounting option		Adapter kit		
					CRC ¹⁾	Part No. Type	
	ERMO	HGPT-B			DHAA		
	12	16	■	■	2	8079169 DHAA-G-R3-12-B8-16	
	12	20	■	■		8079170 DHAA-G-R3-12-B8-20	
	16	16	■	■		8079193 DHAA-G-R3-16-B8-16	
	16	20	■	■		8079195 DHAA-G-R3-16-B8-20	
	25	16	■	■		8079202 DHAA-G-R3-25-B8-16	
	25	20	■	■		8079205 DHAA-G-R3-25-B8-20	
	25	25	■	■		8079207 DHAA-G-R3-25-B8-25	
	32	20	■	■		8079217 DHAA-G-R3-32-B8-20	
	32	25	■	■		8079218 DHAA-G-R3-32-B8-25	
32	35	■	■	8079221 DHAA-G-R3-32-B8-35			
	EHMB	HGPT-B			DHAA, HAPG		
	20	40	■	■	2	537184 HAPG-SD2-26	
	20, 25, 32	50	■	■		564956 DHAA-G-Q5-32-B8-50	
25, 32	63	■	■	537188 HAPG-SD2-28			
	ELCC	HGPT-B			DHAA		
	60	35	■	■	2	5162493 DHAA-G-E21-60-B8-35	
	60	40	■	■		5162495 DHAA-G-E21-60-B8-40	
	60	50	■	■		5162497 DHAA-G-E21-60-B8-50	
	70	40	■	■		2092070 DHAA-G-Q11-32-B8-40	
	70, 90	50	■	■		2118750 DHAA-G-Q11-32-B8-50	
	70, 90, 110	63	■	■		5162500 DHAA-G-E21-70...110-B8-63	
	90, 110	80	■	■		5162502 DHAA-G-E21-70...110-B8-80	
	ELCC	HGPT-B-G				2	DHAA
	60	35	■	■	5162494 DHAA-G-E21-60-B8G-35		
	60	40	■	■	5162496 DHAA-G-E21-60-B8G-40		
	60	50	■	■	5162498 DHAA-G-E21-60-B8G-50		
	70	40	■	■	2597387 DHAA-G-Q11-32-B8G-40		
	70, 90	50	■	■	2597428 DHAA-G-Q11-32-B8G-50		
70, 90, 110	63	■	■	5162501 DHAA-G-E21-70...110-B8G-63			
90, 110	80	■	■	5162503 DHAA-G-E21-70...110-B8G-80			

1) Corrosion resistance class CRC 2 to Festo standard FN 940070
Moderate corrosion stress. Indoor applications in which condensation may occur. External visible parts with primarily decorative requirements for the surface and which are in direct contact with the ambient atmosphere typical for industrial applications.

Parallel grippers HGPT-B, heavy-duty

Accessories

Gripper jaw blank BUB-HGPT
(scope of delivery: 2 pieces)

Material:
Aluminium

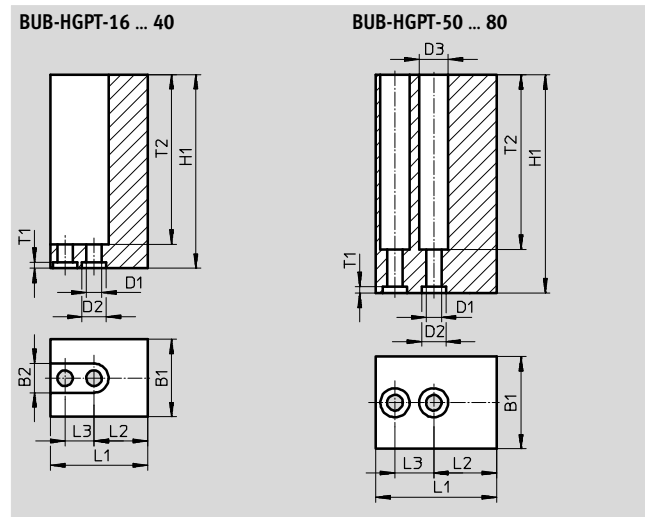

Dimensions and ordering data							
For size	B1	B2	D1	D2	D3	H1	L1
[mm]	±0.05	H13	∅ H13	∅ H8	∅ H13	±0.05	±0.05
16	16	6	3.2	5	-	40	21
20	19	6	3.2	5	-	45	27
25	24	8	4.3	7	-	60	31
35	28	10	5.3	9	-	70	39
40	34	11	6.4	9	-	75	49
50	40	-	6.4	9	11	100	61
63	50	-	10.3	12	17	120	79
80	58	-	12.4	15	20	140	88



For size	L2 ¹⁾	L3 ¹⁾	T1	T2	Weight per blank [g]	Part No.	Type
[mm]			+0.1				
16	10	8	1.3	35	29	560244	BUB-HGPT-16-B
20	11.75	12	1.3	36	53	560245	BUB-HGPT-20-B
25	13.25	13	1.6	51	98	560246	BUB-HGPT-25-B
35	17.5	16	2.1	61	161	560247	BUB-HGPT-35-B
40	22.5	20	2.1	66.5	280	560248	BUB-HGPT-40-B
50	29	24	2.1	91	622	560249	BUB-HGPT-50-B
63	37.5	32	2.6	110	1213	560250	BUB-HGPT-63-B
80	36	40	3.1	125	1738	560251	BUB-HGPT-80-B

1) Tolerance for centring hole ±0.02 mm
Tolerance for thread ±0.1 mm

Parallel grippers HGPT-B, heavy-duty

Accessories

FESTO

Ordering data						
	For size [mm]	Description	Weight [g]	Part No.	Type	PU ¹⁾
Centring sleeve ZBH Technical data → Internet: zbh						
	16, 20	For centring gripper jaw blanks/gripper fingers on the gripper jaws	1	189652	ZBH-5	10
	25		1	186717	ZBH-7	
	35, 40, 50		1	150927	ZBH-9	
	63		1	189653	ZBH-12	
	80		3	191409	ZBH-15	
	20, 25	For lateral centring of gripper fingers on the gripper jaws	1	189652	ZBH-5	
	35, 40, 50, 63		1	186717	ZBH-7	
	80		1	150927	ZBH-9	
	16, 20	For centring the gripper during mounting	1	189652	ZBH-5	
	25, 35		1	186717	ZBH-7	
	40		1	150927	ZBH-9	
	50, 63, 80		1	189653	ZBH-12	
	Connecting sleeve ZBV Technical data → Internet: zbv					
	–	For compensating different centring diameters	1	571033	ZBV-6-5	1
			1	571034	ZBV-8-7	
			1	560253	ZBV-9-8	
			2	571035	ZBV-12-10	
			2	560255	ZBV-14-12	
Blanking plug B Technical data → Internet: blanking plug						
	16, 20	For sealing the supply ports	1	30979	B-M3-S9	10
	25, 35, 40		1	174308	B-M5-B	
	50, 63		5	3568	B-1/8	
	80		15	3569	B-1/4	

1) Packaging unit

Parallel grippers HGPT-B, heavy-duty

Accessories

FESTO



Proximity sensors for size 16 ... 35

Ordering data – Proximity sensors for C-slot, magneto-resistive						Technical data → Internet: smt	
	Type of mounting	Electrical connection, connection direction	Switching output	Cable length [m]	Part No.	Type	
N/O contact							
	Insertable in the slot lengthwise	Cable, 3-wire, lateral	PNP	2.5	547862	SMT-10G-PS-24V-E-2,5Q-OE	
		Plug M8x1, 3-pin, lateral		0.3		547863 SMT-10G-PS-24V-E-0,3Q-M8D	
		Cable, 3-wire, lateral	NPN	2.5	8065030	SMT-10G-NS-24V-E-2,5Q-OE	
		Plug M8x1, 3-pin, lateral		0.3		8065029 SMT-10G-NS-24V-E-0,3Q-M8D	

Proximity sensors for size 40 ... 80

Ordering data – Proximity sensors for T-slot, magneto-resistive						Technical data → Internet: smt	
	Type of mounting	Electrical connection, connection direction	Switching output	Cable length [m]	Part No.	Type	
N/O contact							
	Insertable in the slot lengthwise	Cable, 3-wire, lateral	PNP	2.5	547859	SMT-8G-PS-24V-E-2,5Q-OE	
		Plug M8x1, 3-pin, lateral		0.3		547860 SMT-8G-PS-24V-E-0,3Q-M8D	
		Cable, 3-wire, lateral	NPN	2.5	8065028	SMT-8G-NS-24V-E-2,5Q-OE	
		Plug M8x1, 3-pin, lateral		0.3		8065027 SMT-8G-NS-24V-E-0,3Q-M8D	

Ordering data – Connecting cables

Ordering data – Connecting cables				Technical data → Internet: nebu	
	Electrical connection, left	Electrical connection, right	Cable length [m]	Part No.	Type
	Straight socket, M8x1, 3-pin	Cable, open end, 3-wire	2.5	541333	NEBU-M8G3-K-2.5-LE3
			5		541334
	Angled socket, M8x1, 3-pin	Cable, open end, 3-wire	2.5	541338	NEBU-M8W3-K-2.5-LE3
			5		541341

Position transmitter

Mode of operation:

The position transmitter continuously senses the position of the piston. It has an analogue output with an output signal in proportion to the piston position.

Measuring range:

Measurement is possible across the entire stroke with the sizes 40 and 50. A stroke of 13 mm (with the high-force variant 6.5 mm) can be measured with the sizes 63 and 80.

Projection:

Two position transmitters are required for sensing longer strokes. The position transmitter projects past the housing with the sizes 40 and 50.

Ordering data – Position transmitters for T-slot

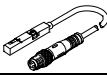
Ordering data – Position transmitters for T-slot							Technical data → Internet: position transmitter		
	For size	Position measuring range	Analogue output		Type of mounting	Electrical connection	Cable length [m]	Part No.	Type
			[V]	[mA]					
	40 ... 80	0 ... 40	0 ... 10	–	Insertable in slot from above	Plug M8x1, 4-pin, in-line	0.3	553744	SMAT-8M-U-E-0,3-M8D

Parallel grippers HGPT-B, heavy-duty

Accessories





Position transmitter

The position transmitter continuously senses the position of the piston.

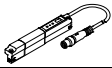
It has an analogue output with an output signal in proportion to the piston position.

Ordering data – Position transmitter for T-slot							Technical data → Internet: position transmitter	
	For size	Position measuring range	Analogue output	Type of mounting	Electrical connection	Cable length [m]	Part No.	Type
			[mA]					
	63, 80	0 ... 50	4 ... 20	Insertable in slot from above	Plug M8x1, 4-pin, in-line	0.3	1531265	SDAT-MHS-M50-1L-SA-E-0.3-M8

Ordering data – Connecting cables				Technical data → Internet: nebu	
	Electrical connection, left	Electrical connection, right	Cable length [m]	Part No.	Type
	Straight socket, M8x1, 4-pin	Cable, open end, 4-wire	2.5	541342	NEBU-M8G4-K-2.5-LE4
			5	541343	NEBU-M8G4-K-5-LE4
	Angled socket, M8x1, 4-pin	Cable, open end, 4-wire	2.5	541344	NEBU-M8W4-K-2.5-LE4
			5	541345	NEBU-M8W4-K-5-LE4